



PRODUCT GUIDE:
**EYEDRO ELECTRICITY
MONITORING PRODUCTS**

CONTENTS

Important Safety Information for Eyedro Monitoring Products.....	5
Additional Safety Information for Electricity Monitoring Products	6
Box Contents (By Product).....	7
Eyedro Business Electricity Monitors	7
Hardware Installation	8
Install Current Sensors	9
Materials You Will Need.....	9
Tools You Will Need	9
Procedure	9
Parallel Feeders	10
Common Circuit Types	11
Wireless Mesh Best Practices (Mesh Products Only).....	17
Mount Eyedro Device(s).....	18
Materials You Will Need.....	18
Tools You Will Need	18
Procedure (Vertical Mount).....	18
Procedure (Horizontal Mount).....	19
Connect Cabling	20
Materials You Will Need.....	20
Tools You Will Need	20
Important.....	20
Procedure (Ethernet Installations)	20
Procedure (Wi-Fi Installations)	21
Procedure (Mesh Installations).....	21
Internet Connection.....	22
Provisioning Eyedro Wi-Fi	23

PRODUCT GUIDE: EYEDRO ELECTRICITY MONITORING PRODUCTS

Materials You Will Need..... 23

Tools You Will Need 23

Procedure (Wi-Fi Devices Only) 23

Tips 24

Software Configuration..... 25

 MyEyedro.com..... 25

Specifications 26

 Hardware Specifications..... 26

 Sensor Specifications 26

 Sensor Specifications (Available Substitutes)..... 27

Compliance 28

Warranty 29

Troubleshooting 30

Contact Information 31

PRODUCT GUIDE: EYEDRO ELECTRICITY MONITORING PRODUCTS

If you have any questions about using your Eyedro Electricity Monitoring System please visit eyedro.com for information, documentation, videos, and answers to frequently asked questions.

**PLEASE READ ALL ENCLOSED INSTRUCTIONS PRIOR TO THE INSTALLATION.
EACH STEP OF THE ENCLOSED INSTRUCTIONS MUST BE FOLLOWED CAREFULLY.**

IMPORTANT SAFETY INFORMATION FOR EYEDRO MONITORING PRODUCTS

The Eyedro Monitoring products (and all components) are designed for **INDOOR USE ONLY** and should be installed inside a suitable building or panel. When installing:

- ❗ **DO NOT** subject the unit or sensors to excessive temperature, humidity, force, shock, or dust.
- ❗ **DO NOT** use or store this product in locations that could adversely affect the product such as rain, snow, or desert.
- ❗ **DO NOT** immerse the unit in water or other liquids. If liquid is spilled over it, remove power, and clean up the spill immediately with a soft, lint-free, cloth and allow all electronics to fully dry before attempting to use.
- ❗ **DO NOT** use this product where the use of radio frequency products can cause interference in other critical control equipment (i.e., hospitals).

The Eyedro Monitoring products (and all components) are **NOT USER SERVICEABLE**. Please contact Eyedro Green Solutions Inc. if any component appears damaged or faulty.

- ❗ **DO NOT** open the case of the unit or tamper with any of the internal or external components.
- ❗ **DO NOT** attempt to repair the product by yourself.
- ❗ **DO NOT** dispose of this product in your household waste. At the end of its serviceable life please ensure product is disposed of according to local electrical and electronics equipment disposal practices.

The following notes apply to Eyedro Wireless products:

This equipment has been tested and found to comply with the limits for a Class A digital device, pursuant to part 15 of the FCC Rules. These limits are designed to provide reasonable protection against harmful interference in a residential installation. This equipment generates, uses and can radiate radio frequency energy, and if not installed and used in accordance with the instructions, may cause harmful interference to radio communications. However, there is no guarantee that interference will not occur in a particular installation. If this equipment does cause harmful interference to radio or television reception, which can be determined by turning the equipment off and on, the user is encouraged to try to correct the interference by one or more of the following measures:

Reorient or relocate the receiving antenna.

Increase the separation between the equipment and receiver.

Connect the equipment into an outlet on a circuit different from that to which the receiver is connected.

Consult the dealer or an experienced radio/TV technician for help.

To satisfy FCC RF Exposure requirements for mobile and base station transmission devices, a separation distance of 20 cm or more should be maintained between the antenna of this device and persons during operation. To ensure compliance, operation at closer than this distance is not recommended. The antenna(s) used for this transmitter must not be co-located or operating in conjunction with any other antenna or transmitter.

ADDITIONAL SAFETY INFORMATION FOR ELECTRICITY MONITORING PRODUCTS

It is important that you observe some simple safety precautions when installing Eyedro Electricity Monitoring products. The Eyedro Electricity Monitor was designed to be non-intrusive and easy to install. Typically, there is no need to disconnect any electrical cabling during the installation. However, there are several safety issues that should be considered when installing and using the system.



UNSURE ABOUT HANDLING ELECTRICAL WIRING? CONSULT A QUALIFIED ELECTRICIAN FOR SENSOR INSTALLATION.

WARNING: To reduce the risk of electric shock, always open or disconnect circuit from power-distribution system (or service) of building before installing or servicing current sensors, metering equipment, or sub-metering equipment.

Installation may require the cover of the main electrical panel to be removed while some wires are still electrified. Even when the main breaker has been turned 'OFF' certain areas of the panel may still be dangerous and carry the risk of shock, burn, and electrocution. **Installation should be performed by qualified electrician or duly qualified personnel where required by law. Check with your local authority having jurisdiction for permit and inspection requirements. DO NOT attempt installation unless you know where electrified areas within the panel are.**

The **current sensors** clip on to the live cables which supply electricity to your electrical panel and/or branch circuits and loads. When installing these sensors:

- ❗ **DO NOT** install the sensor onto a cable whose current exceeds the rated current of the sensor.
- ❗ **DO NOT** install the sensor onto cabling that is loose, wet, or appears damaged (cracked, burned, bare copper or missing insulation). Contact a qualified electrician and/or your electricity supplier to report your findings.
- ❗ **DO NOT** bend or force the cables during installation.
- ❗ **DO NOT** force the sensor onto the cabling if the cable diameter appears to be too large.

BOX CONTENTS (BY PRODUCT)

EYEDRO BUSINESS ELECTRICITY MONITORS

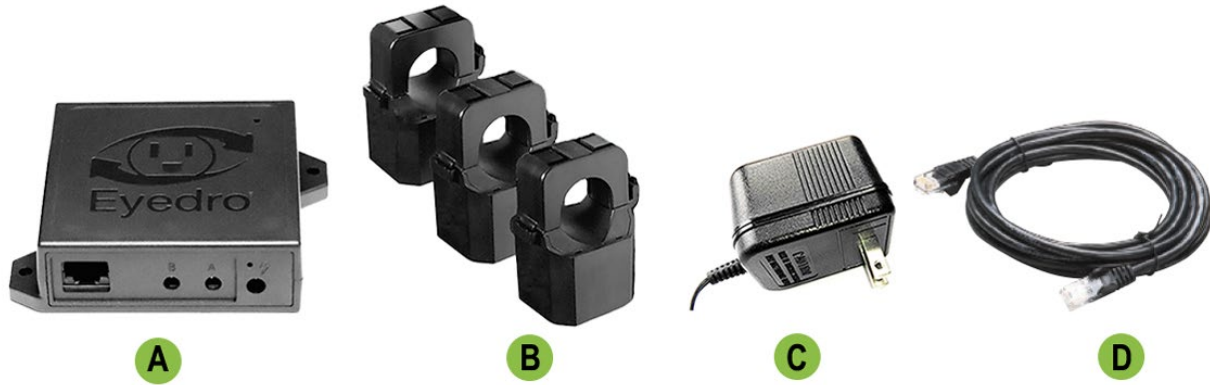

	Ethernet + Wi-Fi	Mesh	Description
A	1	-	Eyedro Ethernet/Wi-Fi Electricity Module (EMx.ENWI.*E)
	-	1	Eyedro Mesh Electricity Module (EMx.NODE.*E)
	-	0 - 1 ¹	Eyedro Mesh Gateway Module (EMx.GATE.ON)
B	1-3 ²	1-3 ²	Current Sensors (200A sensors shown ³)
C	1	1 - 2 ¹	Low-voltage Power Adapter (Wall mount North American model shown ³)
D	10ft (3m)	3ft (0.9m) ¹	Ethernet Cable

¹ Gateway, (1) power supply and Ethernet cable are not included in Wireless Expansion products (ExB-M-*)

² Number of sensors supported depend on model. ExB-*E3 = 3, ExB-*E2 = 2, ExB-*E1 = 1

³ 200A (part number ESCLV-25-200A) standard product. Substitutions available up to 3000A

HARDWARE INSTALLATION



DO NOT CONTINUE WITH THE INSTALLATION OF THE EYEDRO ELECTRICITY MONITORING SYSTEM UNTIL YOU HAVE READ THE SAFETY SECTION OF THIS GUIDE.

INSTALL CURRENT SENSORS

MATERIALS YOU WILL NEED

- Eyedro Current Sensors
- Approved bushing or connector (not included)
- Labels (optional – not included)

TOOLS YOU WILL NEED

- Flashlight
- Screwdriver
- Pliers

PROCEDURE

Current sensors are **installed on the individual line (/live/hot) conductors only**. This must be done inside the electrical panel or junction box where the electrical connection is separated into the individual line, neutral and ground conductors.

- ❗ **Do not** install sensors on **neutral or ground conductors**.
- ❗ **Do not** install sensors on **extension cords, appliance cords or sheathed cables**.
- ❗ **Do not** install sensors on **conductors exceeding the max rating of the sensor**.

1. Turn off the power by disengaging the main disconnect switch or turning off the main breaker.



CAUTION: EVEN WITH THE MAIN BREAKER IN THE 'OFF' POSITION, THE SERVICE ENTRANCE WIRES WILL STILL BE ELECTRIFIED (BEFORE THE BREAKER). EXTREME CAUTION SHOULD ALWAYS BE TAKEN WHILE WORKING AROUND ELECTRICITY.

2. Carefully remove the electrical panel cover(s) to expose the conductors.
3. Carefully remove a 'knockout' on the side of the panel and add an approved bushing or connector to protect the low voltage signal wires that will pass through it.
4. Install one current sensor over **each line conductor**. Use the figures indicated in [common circuit types](#) as guidance.
 - ❗ If installing over a single conductor of a parallel feed, ensure the ampacity of a single conductor (i.e., total ampacity / feeders) does not exceed the rating of the sensor.
5. Optionally, use tape or other label to uniquely identify each sensor at the end of the wire nearest the connector (i.e., "Sensor 1", "Phase A", etc.).
6. Route sensor cables through the bushing/connector so the plug ends are on the exterior of the panel.
7. If provided (sold separately), install panel mount power supply or step-down transformer prior to replacing the panel cover(s) and route the low voltage side through the bushing/connector so the plug is on the exterior of the panel.
 - ❗ **IMPORTANT: Electricity monitoring devices must be powered by a circuit or receptacle that is downstream of the panel where the current sensors are installed**
8. Replace panel cover(s).
9. Turn on the power.

PARALLEL FEEDERS

High ampacity services and feeders are often installed with conductors in parallel to reduce pulling tensions and for easier handling.

Parallel feeders are conductors of the same length, same material, same circular mil area, same insulation, and terminated in the same manner. In theory, the current flowing through each conductor will be the same and can be determined by the total ampacity divided by the number of feeder conductors i.e., $1600A / 4 \text{ conductors} = 400A \text{ per conductor}$.

The most accurate way to measure would be with a single large sensor around all the parallel conductors. However, if you want to use a single smaller sensor to monitor you must ensure the following:

1. The per conductor ampacity does not exceed the rating of the sensor.
2. The number of feeders is noted and set as the current multiplier during setup in the MyEyedro software.

COMMON CIRCUIT TYPES

The most common application of Eyedro Electricity Monitoring products is for monitoring of the electrical service entrance of a building. However, there are other common applications where Eyedro Electricity Monitoring products are often used. The following sub-sections provide a brief overview of some of the common and less common applications.

To use Eyedro Electricity Monitoring products in one of these applications, follow ALL instructions and precautions from the [current sensor installation procedure](#) but substitute step 4 to install the sensors on the **line conductor** of your desired circuit.

3-PHASE WYE MONITORING

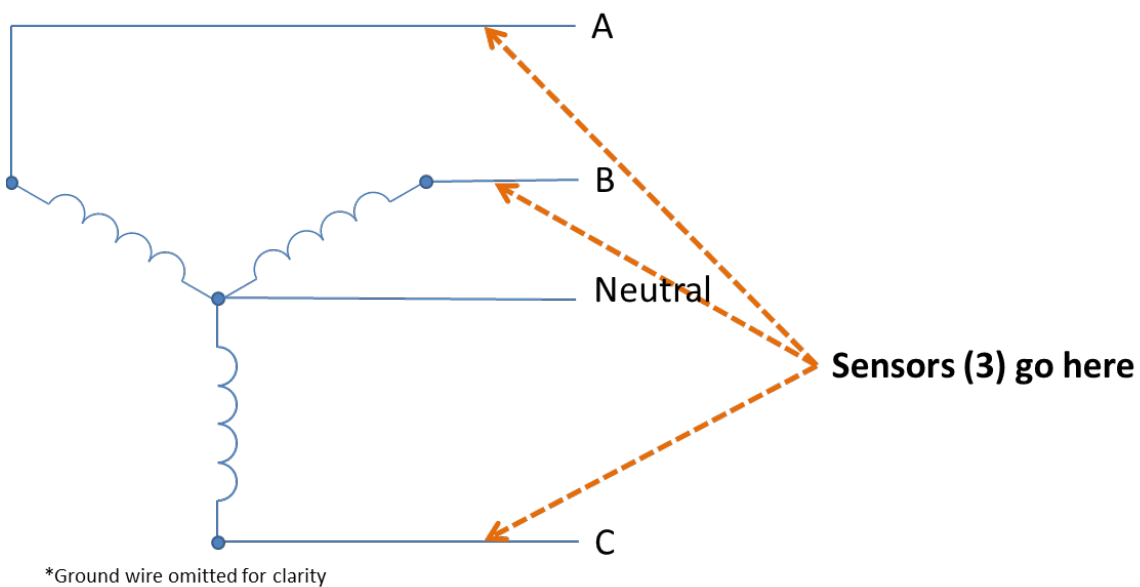

3-PHASE DELTA MONITORING

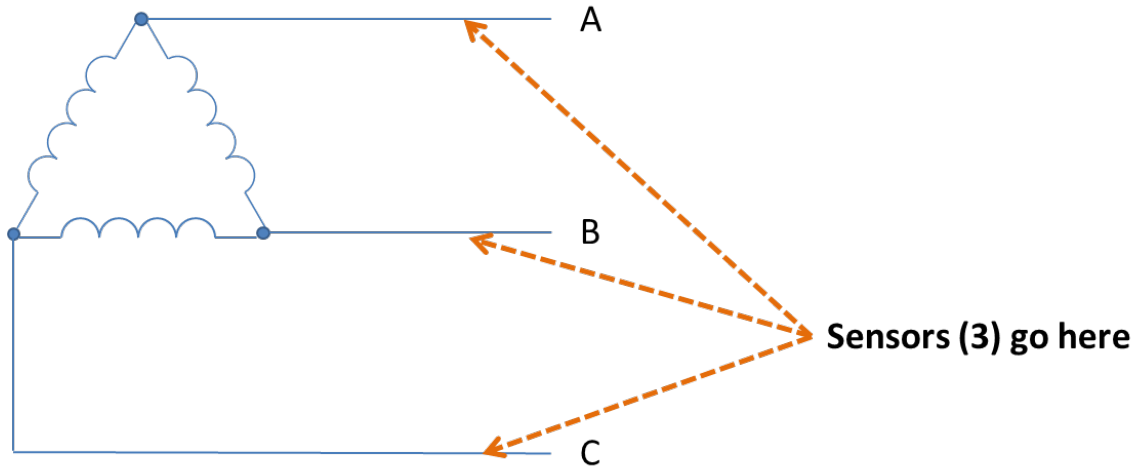

*Ground wire omitted for clarity

Note: The sensor position is the same for Delta, High-Leg Delta or Corner Grounded Delta systems.

SPLIT (SINGLE) PHASE MONITORING

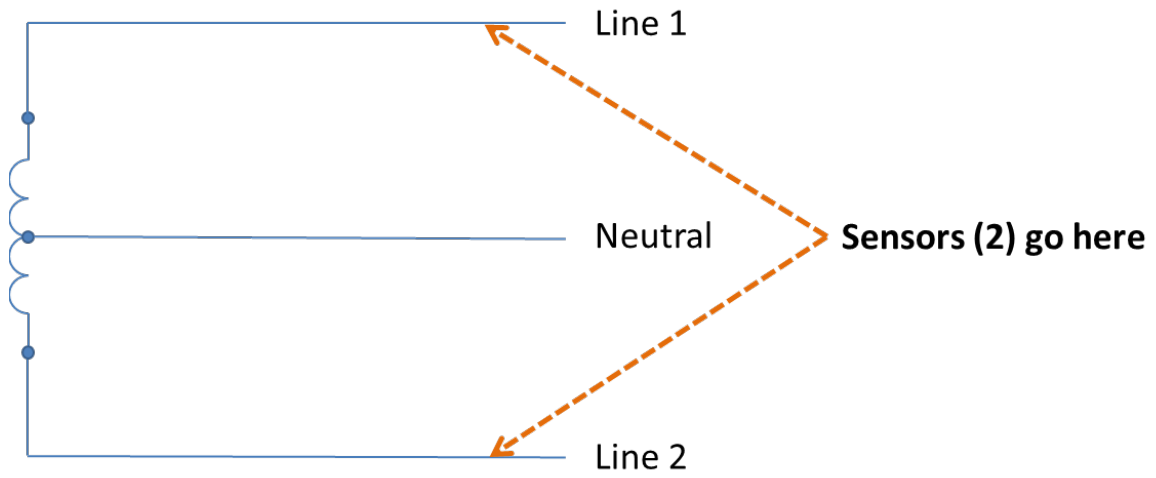

*Ground wire omitted for clarity

SINGLE PHASE BRANCH CIRCUIT MONITORING

Branch circuits are commonly used for lighting and receptacles throughout the building. These circuits can be identified by a single-pole breaker in the electrical panel. Cabling typically consists of black (line) and white (neutral) conductors with a bare copper (or green) ground conductor.

One (1) sensor is required for monitoring single phase branch circuits or loads. The sensor should be installed on the line conductor of the circuit (often black).

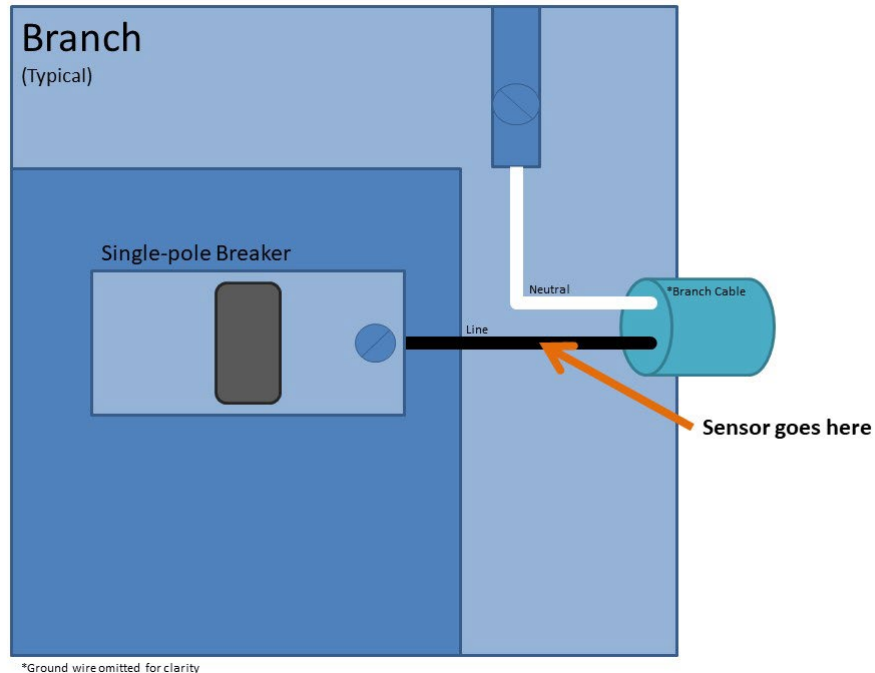

BALANCED BRANCH CIRCUIT MONITORING

Balanced branch circuits are commonly used for electric heaters/baseboards, electric water heaters, air conditioners, heat pumps, pool pumps, etc. These circuits can be identified by a double-pole breaker in the electrical panel. Cabling typically consists of black (line 1) and red (line 2) conductors with a bare copper (or green) ground conductor. **Note: these circuits do not have white (neutral) conductors.**

One (1) sensor is required for monitoring balanced branch circuits. The sensor should be installed on either line conductor of the circuit (typically black or red).

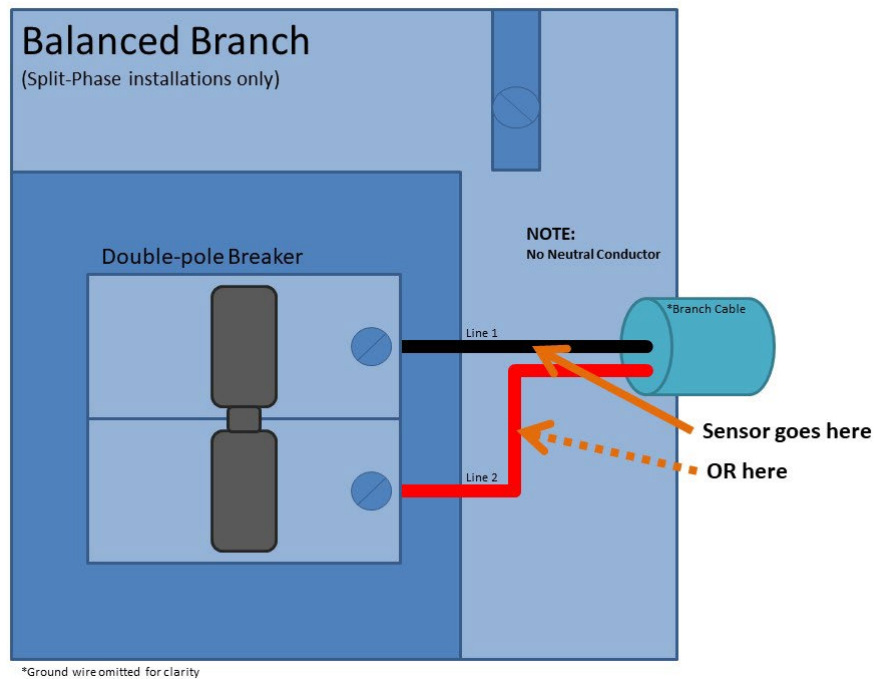

UNBALANCED BRANCH CIRCUIT MONITORING

Unbalanced branch circuits are commonly used for large loads with multiple voltage requirements, split receptacles, and sub-panel feeders throughout the building. These circuits can be identified by a double-pole breaker in the electrical panel. Cabling typically consists of black (line 1), red (line 2), and white (neutral) conductors with a bare copper (or green) ground conductor.

A typical split-phase residential service entrance is an example of a 240V unbalanced circuit.

Two (2) sensors are required for monitoring unbalanced circuits. The sensors should be installed on both line conductors of the circuit (typically black and red).

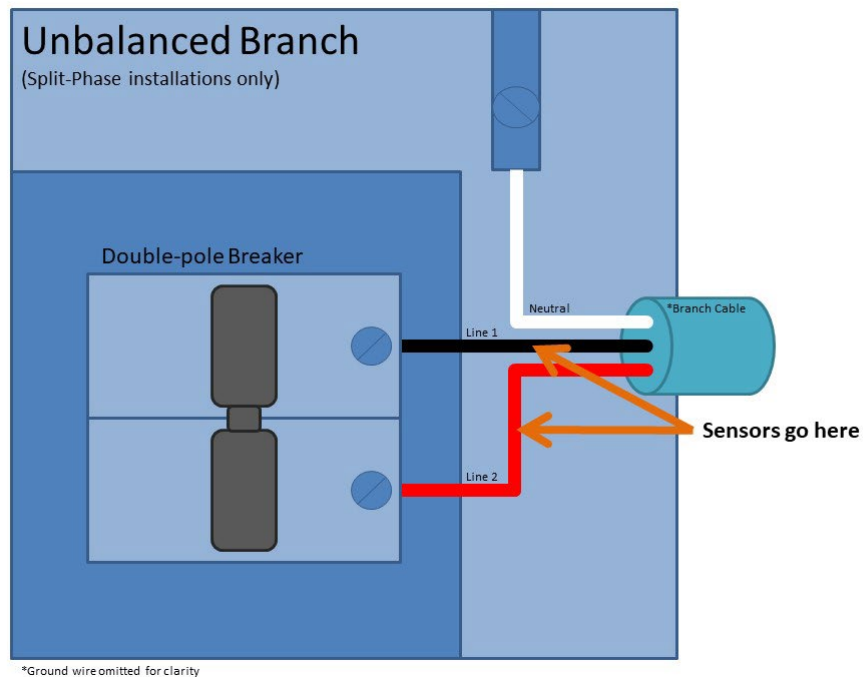

WIRELESS MESH BEST PRACTICES (MESH PRODUCTS ONLY)

Eyedro Mesh Electricity Monitoring (ExB-M*) products have all the same features as the non-wireless version but do not require a network connection near the point where the sensors are installed. The modules will communicate with each other over their own **private wireless network** so that the sensors can be installed where you need them, and the gateway module can be located near an available RJ45 Ethernet network connection.

Eyedro mesh products operate on a custom wireless protocol operating on the **2.4GHz** frequency band. Operating range varies for each installation depending on the distance between and the number (and material) of obstructions the wireless communication must pass through and how much other wireless traffic there is in the area.

To achieve the best performance in wireless installations the following guidelines should be followed:

1. Minimize the number of obstructions between modules where possible (interior/exterior walls, floors, windows, trees, etc.). Line of sight provides the best performance.
2. Minimize the number of 2.4GHz radiators near the modules and in the surrounding environment (Wi-Fi routers, Wi-Fi devices, Bluetooth devices, microwaves, ZigBee/IEEE 802.15.4 wireless devices).
3. If multiple Eyedro mesh devices are in the same area, create a physical separation between the modules. There should be a minimum separation of at least 24" (60cm).
4. If using a Wi-Fi bridge device for connectivity, create a physical separation between Eyedro module(s) and Wi-Fi bridge. There should be a minimum separation of at least 24" (60cm). If possible, plug the two devices into separate receptacles.
5. Modules should be secured in position with screws, Velcro tape or by other means. Do not let the device hang by the wires. Doing so may affect the signal quality and/or cause damage.
6. Keep the area around the Eyedro module free from metallic objects.
7. Do not mount the Eyedro module on the metal electrical panel - if unavoidable, put an insulating material, like wood or foam, between the Eyedro module and the metal.
8. Do not seal the Eyedro module in the electrical panel or other metal enclosure.

MOUNT EYEDRO DEVICE(S)

MATERIALS YOU WILL NEED

- Two (2) #8 (4.2mm) pan head or round head mounting screws (optional – not included)
- Double-sided tape (optional – not included)

TOOLS YOU WILL NEED

- Screwdriver

PROCEDURE (VERTICAL MOUNT)

1. Write down the 8-digit serial number from the back of the module. This will be required during software setup.

❗ The serial number will be in the format "**123 - 45678**"

2. Find a clear area on the wall beside the electrical panel (or router in the case this is the Eyedro Wireless Gateway Module).

❗ Make sure all cables will easily reach the module before securing.

❗ Equipment shall not be mounted within 50.8 mm (2 in) in of any live parts including primary conductors, primary terminals, primary lugs. This requirement excludes insulated cables.

❗ Equipment attached to the enclosure shall not contact the panel interior insulation.

❗ Mounting provisions shall not be attached to any live part.

❗ Do not install equipment in any area where breaker arc venting exhaust gasses could be re-directed as a result of equipment installation.

3. Secure the module using either:

- a) Screws (recommended method)

- i. Drive two (2) screws into the wall surface through the flange holes on the sides of the enclosure.

- ii. **Carefully** tighten the screws until snug. Do not overtighten or it may cause damage to the flange(s).

- iii. Ensure secure fit.

- b) Double-sided tape

- i. Cut several pieces of double-sided tape and place on back of module.

- ii. Peel tape backing off.

- iii. Press module carefully but firmly against surface to be mounted on.

- iv. Hold in place as per tape instructions.

- v. Ensure module is held securely in place.

PROCEDURE (HORIZONTAL MOUNT)

Mounting is not required for horizontal installations (i.e., on a desktop or shelf). If added security is desired, follow instructions for vertical mounting using screws or double-sided tape.

CONNECT CABLING

MATERIALS YOU WILL NEED

- Ethernet cable
- Low-voltage power adapter(s)
- Tie wraps (optional – not included)

TOOLS YOU WILL NEED

- None

IMPORTANT

- ❗ Ensure all connectors and sockets are free from damage prior to mating them.
- ❗ If applicable, ensure the retention clip on the Ethernet cable is intact.
- ❗ Never force connectors or apply levering action.
- ❗ Ensure all connections are secure.
- ❗ For devices with both Ethernet and Wi-Fi (ExB.ENWI.*E), the **Ethernet cable must be plugged in before power** is applied to the device for Ethernet communication to be used.

PROCEDURE (ETHERNET INSTALLATIONS)

1. Connect sensor cables to the Eyedro module.
2. Connect one end of Ethernet cable to Eyedro module.
3. Connect the other end of the Ethernet cable to the router (or Internet access point).
4. Connect the appropriate end of the low-voltage power adapter to the Eyedro module.
 - ❗ Electricity monitoring devices (with sensors) use a power supply with a **6V AC** output.
5. Plug the other end of the low-voltage power adapter into a nearby AC wall receptacle.
 - ❗ Devices should not be plugged into a UPS (Uninterruptible Power Supply) as they may result in inaccurate/incorrect measurements.
 - ❗ Electricity monitoring devices (with sensors) must be powered by a receptacle that is downstream of the panel where the current sensors are installed.
6. Secure all wiring neatly with tie wraps.

PROCEDURE (WI-FI INSTALLATIONS)

1. Connect sensor cables to the Eyedro module.
2. Connect the appropriate end of the low-voltage power adapter to the Eyedro module.
 - ❗ Electricity monitoring devices (with sensors) use a power supply with a **6 V AC** output.
3. Plug the other end of the low-voltage power adapter into a nearby AC wall receptacle.
 - ❗ Devices should not be plugged into a UPS (Uninterruptible Power Supply) as they may result in inaccurate/incorrect measurements.
 - ❗ Electricity monitoring devices (with sensors) must be powered by a receptacle that is downstream of the panel where the current sensors are installed.
4. Secure all wiring neatly with tie wraps.

PROCEDURE (MESH INSTALLATIONS)

1. Connect one end of Ethernet cable to **Eyedro Gateway module**.
2. Connect the other end of the Ethernet cable to the router (or Internet access point).
3. Connect the appropriate end of the low-voltage power adapter to the Eyedro Gateway module.
 - ❗ Gateway devices use a power supply with a **5VDC** output.
4. Plug the other end of the low-voltage power adapter into a nearby AC wall receptacle.

5. Connect sensor cables to the **Eyedro Sensor Module(s)**.
6. Connect the appropriate end of the low-voltage power adapter to the Eyedro Sensor Module.
 - ❗ Electricity monitoring devices (with sensors) use a power supply with a **6 V AC** output.
7. Plug the other end of the low-voltage power adapter into a nearby AC wall receptacle.
 - ❗ Devices should not be plugged into a UPS (Uninterruptible Power Supply) as they may result in inaccurate/incorrect measurements.
 - ❗ Electricity monitoring devices (with sensors) must be powered by a receptacle that is downstream of the panel where the current sensors are installed.

8. Secure all wiring neatly with tie wraps.

INTERNET CONNECTION

All Eyedro products are designed to take advantage of the MyEyedro cloud services – thus requiring the product(s) to be always connected to the internet. There is a small amount of internal memory to store data in the event of a temporary disruption to your internet service.

For most networks, it only requires that you connect the device to the network with a DHCP server somewhere on the network. A DHCP server is enabled on most routers by default and will provide connected hardware with an IP address so they can communicate via the internet.

In some cases, additional security has been added to the local network (firewall, port filtering, etc.) making some additional configuration necessary. A good test would be to plug a laptop or computer into the same Ethernet port that you intend to use for your (wired) Eyedro product, or, if installing a Eyedro Wi-Fi product, provision it to connect to the same Wi-Fi network – if you can open a browser and navigate the web no additional configuration is likely needed.

A couple of important notes:

- **Wi-Fi** devices utilize the **2.4GHz** frequency band. Ensure your Wi-Fi router supports 2.4GHz devices.
- For devices with both Ethernet and Wi-Fi (ExB.ENWI.*E), the **Ethernet cable must be plugged in before power** is applied to the device for Ethernet communication to be used.
- Ethernet devices require connection to an **active Ethernet port** on your router, switch, or hub.
- Ethernet devices ship with Ethernet patch cords (straight-through). Most routers, switches and hubs provide crossover functionality, but some old hardware may not. In those cases, it may be necessary to connect to a specific port or use a crossover cable.
- Ethernet devices communicate via **Half-Duplex 10Base-T**. Most routers, switches and hubs provide coexistence, but some may not. In those cases, it may be necessary to configure the connected port appropriately.
- All devices require a **DHCP server** somewhere on the network.
- If your network does not have a DHCP server, or it is restricted, you may need to reserve an IP address for the device based on the MAC address of the device.
- The **MAC address** of your device will be **60:54:64:XX:YY:ZZ** – where XX:YY:ZZ are based on digits of your module serial number. For example, a module with the serial number **123-45678** will have the MAC address 60:54:64:**12:36:78**. Devices with both Ethernet and Wi-Fi will substitute the first device specific digit with 'E' for the Ethernet MAC (the Wi-Fi MAC will remain the same) – the above example will become 60:54:64:E2:36:78.
- All devices communicate using **port 80 (HTTP)** – all communication to/from the device looks like standard **web traffic**.
- If you have changed the DNS settings in your router (i.e., to use an ad blocker), try switching back to use the default settings. Alternately use Google's DNS servers 8.8.8.8 (primary) and 8.8.4.4 (secondary)
- Eyedro Mesh products (ExB-M*) do **not** communicate using the **Wi-Fi** protocol. They use a custom wireless protocol between modules and the gateway unit plugs into a physical Ethernet port, on your router or switch, to access the internet.

PROVISIONING EYEDRO WI-FI

MATERIALS YOU WILL NEED

- None

TOOLS YOU WILL NEED

- Phone, tablet, or computer (to connect to the device's network)

PROCEDURE (WI-FI DEVICES ONLY)

1. Using a phone, tablet, or computer, disconnect from your current Wi-Fi network.
 - ❗ It may be necessary to explicitly deselect 'auto-connect'. Failing to do so may cause the provisioning device to switch back to its original network during provisioning.
 - ❗ If your device has an alternate path to the internet (i.e., cellular), it may be necessary to disable that network connection during provisioning (i.e., turn off cellular).
 - ❗ It may be necessary to temporarily disable your virus scanner during provisioning.
2. Using the same phone/tablet/computer, search for available Wi-Fi networks and connect to the Wi-Fi network created by your Eyedro device.
 - ❗ The name of the created network will be "Eyedro[xxx-yyyyy]" where xxx-yyyyy matches the serial number of the device.
3. Open a browser and go to eyedro.com/setup.
 - ❗ If not automatically redirected to the setup page, it may be necessary to enter **192.168.1.1** in the browser URL.
 - ❗ On some mobile devices, you may get a message indicating 'Sign in'. Click sign in and you should be redirected to the setup page. If not, refresh the page and/or open a browser and browse to eyedro.com/setup or 192.168.1.1.
4. Input the Wi-Fi credentials (Network SSID and Password) for the network you would like the device to connect to in the appropriate fields and click **Connect**.

Eyedro Wi-Fi Settings

Network (SSID):

Show Password:

Password (Key):

IMPORTANT

- Network (SSID) and Password (Key) are **case sensitive**
- Network (SSID) is the name of the network used to connect the device to the internet
- Password (Key) is the password, pass-phrase or security key used to access the specified network (blank = Open Network)
- When device successfully connects to your network, its SSID (EyedroWiFi [sn]) will disappear from your available network list
- If the device is unable to connect to your network, see the [EYEFI Setup](#) page for troubleshooting tips

Copyright © 2016-2022 Eyedro Green Solutions Inc. Sensors Network Dashboard

5. Reconnect your phone, tablet, or computer to your original Wi-Fi network. Don't forget to re-enable your cellular connection and/or virus scanner if you turned them off during provisioning.

Important note: If the setup is not successful, the device will recreate its own network and reappear in your available network list. Your device must be connected to the internet before you will be able to claim it on your MyEyedro Account.

TIPS

When applying power to the device it will run through its startup tests. Approximately 10 seconds after power has been applied, the status lights will indicate the status of the communication:

- **Red/Green** (both) toggle 2 seconds on/off = **Not connected**.
SSID, "Eyedro [xxx-yyyy]", should be visible in your available Wi-Fi network list.
- **Green** toggle 2 seconds on/off = **Connected**.
Device is connected to the provisioned network and should appear as 'Active' in MyEyedro.

If the status lights are still not green (connected) after following the procedure, cycle power to the Eyedro device and try the procedure again – carefully following all instructions and notes.

Wi-Fi connection videos can be found online at the following links:

Eyedro Wi-Fi connection setup via Desktop: [video link](#)

Eyedro Wi-Fi connection setup via mobile: [video link](#)

Additional tips and troubleshooting advice can be found online at:

Website: eyedro.com

Support: eyedro.com/support

How To: <https://eyedro.com/how-to-connect-an-eyefi-to-the-internet/>

Troubleshooting: eyedro.com/support-troubleshooting

SOFTWARE CONFIGURATION

MYEYEDRO.COM



The **MyEyedro** cloud service is the interface for your Eyedro device(s). Eyedro and MyEyedro are always working together to measure, analyze and store your usage and cost information. With MyEyedro, your data is automatically and securely stored in the cloud, so it's ready when and where you need it most. MyEyedro presents your data in ways that are engaging, informative and easy to understand. See real-time usage and gain access to many helpful features, including:

- Responsive real-time graphs
- Hourly/Daily/Weekly/Monthly cost estimates
- Comparisons and estimates
- Configurable reports

MyEyedro is easy to use and accessible from a standard web browser.

1. Go online to: <http://my.eyedro.com> to create your online account (or login if you have an existing account).
2. From the system configuration screen, enter the serial number of your Eyedro Module(s) – found on the back of the device(s).

For more information on MyEyedro and complete instructions for adding devices, refer to the online documentation and user guide found at <http://eyedro.com/support>

SPECIFICATIONS

HARDWARE SPECIFICATIONS

	Ethernet + Wi-Fi	Mesh ¹
Power Supply	Class 2 Power Supply Input: 120Vac, 60Hz (North America/Type A) Input: 240Vac, 50Hz (Europe/Type C) Output: 6Vac, 0-350mA	
Ambient Operating Conditions	0°C to 50°C (32°F to 122°F) 80% relative humidity	
Storage Conditions	-20°C to 70°C (-4°F to 158°F) 80% relative humidity	
Module Dimensions (W x H x D)	77 x 75 x 25 mm (3 x 3 x 1 in)	
Parts Included	1x EMx.ENWI.*E 1-3x Current Sensors 1x 10ft Ethernet Cable 1x 6V AC Power Adapter	1x EMx.NODE.*E 1-3x Current Sensors 1x 6V AC Power Adapter 1x EMx.GATE0N* ¹ 1x 3ft Ethernet Cable ¹ 1x 5V DC Power Adapter ¹
Weight [approximate]²	0.800 kg (1.8 lbs)	0.953 kg (2.1 lbs)
Wireless Link	IEEE 802.11 b/g/n 2.412 to 2.484 GHz	IEEE 802.15.4 2.405 to 2.480 GHz
Wireless Range [typical]³	Indoors: 50m (150ft) Line of sight: 100m (300ft)	Indoors: 150m (500ft) Line of sight: 300m (1000ft)

¹ Gateway, (1) Power Supply and Ethernet cable are not included in Wireless Expansion products (ExB-M-*E)

² Approximate weight is based on standard two (2) sensor models including packaging and contents. Mesh assumes complete system (gateway and node).





³ Wireless range is dependent on the location and environment that device(s) are installed in. Typical values provided.

SENSOR SPECIFICATIONS

Sensor	Input	Output	Accuracy	Core	Opening		Cable Length
200A (ESCLV-25-200A)	0 to 200Aac 600V 50/60Hz	0 to 0.333Vac	±1% Typical ¹	Ferrite	19.00 mm (0.75 in)		2000 mm (79 in)

¹Accuracy noted is for sensor readings at 10% to 90% of rated current. This product also requires a continuous internet connection.

SENSOR SPECIFICATIONS (AVAILABLE SUBSTITUTES)

Sensor	Input	Output	Accuracy	Core	Opening		Cable Length		
5A (XH-SCT-T06-5)	0 to 5Aac 250V 50/60Hz	0 to 0.333Vac	±1% Typical ¹	Ferrite	6.0 mm (0.24 in)		2500 mm (98 in)		
10A (XH-SCT-T06-10A)	0 to 10Aac 250V 50/60Hz								
15A (XH-SCT-T06-15A)	0 to 15Aac 250V 50/60Hz								
20A (XH-SCT-T06-20A)	0 to 20Aac 250V 50/60Hz								
30A (XH-SCT-T06-30A)	0 to 30Aac 250V 50/60Hz								
40A (XH-SCT-T06-40A)	0 to 40Aac 250V 50/60Hz								
60A (XH-SCT-T06-60A)	0 to 60Aac 250V 50/60Hz								
100A (XH-SCT-T18-100A)	0 to 100Aac 600V 50/60Hz			18.0 mm (0.71 in)					
200A (XH-SCT-075-200)	0 to 200Aac 600V 50/60Hz								
400A (XH-SCT-125-400A)	0 to 400Aac 600V 50/60Hz			Steel	19 x 19 mm (0.75 x 0.75 in)				
600A (XH-SCT-125-600A)	0 to 600Aac 600V 50/60Hz							31 x 31 mm (1.25 x 1.25 in)	
800A (XH-SCT-200-800A)	0 to 800Aac 600V 50/60Hz								
1200A (XH-SCT-200-1200A)	0 to 1200Aac 600V 50/60Hz								
2000A (XH-SCT-300-2000A)	0 to 2000Aac 600V 50/60Hz							76 x 127 mm (3.0 x 5.0 in)	
3000A (XH-SCT-300-3000A)	0 to 3000Aac 600V 50/60Hz								

¹Accuracy noted is for sensor readings at 10% to 90% of rated current. This product also requires a continuous internet connection.

COMPLIANCE

This product has been tested and found in compliance to:

Safety Requirements for Electrical Equipment For Measurement, Control, And Laboratory Use -

Part 1: General Requirements [UL 61010-1:2012 Ed.3+R:19Jul2019]

Safety Requirements for Electrical Equipment For Measurement, Control, And Laboratory Use
– Part 1: General Requirements (R2017) [CSA C22.2#61010-1-12:2012 Ed.3+U1;U2]

CAN ICES-3 (B)/NMB-3(B); ISED Canada ICES-003, Issue 6, Class B – Information Technology
Equipment (Including Digital Apparatus).

Federal Communications Commission (FCC), Part 15, Subpart B, Class B - Unintentional Radiators.

This device complies with Part 15 of the FCC Rules. Operation is subject to the following two conditions:
(1) this device may not cause harmful interference and (2) this device must accept any interference
received, including interference that may cause undesired operation.

WARRANTY

LIMITED ONE YEAR WARRANTY

Eyedro Green Solutions Inc. shall provide warranty for all defects in material and workmanship for a period of one year from the original date of purchase. Defective parts may be repaired or replaced, at the discretion of the manufacturer, free of charge during this period.

Warranty Conditions:

1. The product must be installed and operated in strict accordance with the provided instructions.
2. The product must be installed and operated in strict accordance with the operating conditions.
3. Warranty claims require original proof of purchase. A photo of the product may also be requested.
4. Warranty is void if the product has been tampered with or modified in any way.
5. Warranty returns require a Return Material Authorization (RMA) number. Visit eyedro.com/support for an RMA number.
6. Warranty excludes shipping fees outside of the continental United States and Canada 7 days after shipment.

TROUBLESHOOTING

Device installation is simple and non-invasive but occasionally problems do arise. Before contacting support, please refer to our online troubleshooting resources.

Troubleshooting: eyedro.com/support-troubleshooting

CONTACT INFORMATION

If you have any questions about using your Eyedro Electricity Monitoring System please visit our website for documentation, videos, frequently asked questions, and contact forms.

Website: eyedro.com

Support: eyedro.com/support



Eyedro Green Solutions Inc.
550 Parkside Drive, Unit B1
Waterloo, ON N2L5V4

COPYRIGHT © 2011-2023 EYEDRO GREEN SOLUTIONS INC. ALL RIGHTS RESERVED.
THIS DOCUMENT, AND ALL ITS CONTENTS, MAY NOT BE MODIFIED, DISTRIBUTED, COPIED, OR REPRODUCED IN ANY FORM, IN PART OR IN WHOLE, WITHOUT THE EXPRESS WRITTEN CONSENT OF EYEDRO GREEN SOLUTIONS INC.

THE EYEDRO ELECTRICITY MONITORING SYSTEM IS INTENDED TO BE USED TO INCREASE AWARENESS OF ELECTRICITY CONSUMPTION WITHIN THE BUILDING AND AS AN ADDITIONAL RESOURCE TO APPROXIMATE UTILITY COSTS. SYSTEM ACCURACY DEPENDS ON A NUMBER OF FACTORS INCLUDING (BUT NOT LIMITED TO): MEASUREMENT AMPLITUDE, SENSOR CALIBRATION, UP TIME, AND STABILITY OF THE VOLTAGE SUPPLY. IT IS NOT INTENDED TO REPLACE THE ELECTRICITY METER FOR THE BUILDING.

EYEDRO GREEN SOLUTIONS INC. RESERVES THE RIGHT TO MAKE CHANGES TO THE PRODUCTS, SPECIFICATIONS, AND/OR DOCUMENTATION AT ANY TIME WITHOUT NOTICE.

IMAGES AND/OR INSTRUCTIONS DETAILED IN THIS DOCUMENT MAY DIFFER FROM THE ACTUAL PRODUCT HARDWARE AND/OR SOFTWARE.